

MRH-S300A TYPE MAJOR SPECIFICATIONS

Overall length	m	20.8	No.1 conveyor	Center chain conveyor
Overall height	m	4.7	Conveyor width	m 0.75
Overall width	m	4.0	Conveyor speed	m/min 36/43-50/60Hz
Total weight	ton	95	No.2 conveyor	Belt conveyor
Cutting height	m	6.5	Belt width	m 0.9
Cutting width	m	7.5	Conveyor speed	m/min 61/73-50/60Hz
Under cut	m	0.45	Travel speed	m/min High 13/14-50/60Hz Low 6.5/7.5-50/60Hz
Cutting motor(Rated)	kW	300/150-4/8P		
Hydraulic motor(Rated)	kW	90-4P	Crawler shoe width	m 0.75
Total installed power	KW	396.3	Track width	m 3.1
Drum revolution	min ⁻¹	High 36/43-50/60Hz	Ground pressure	MPa 0.16
		Low 18/22-50/60Hz	Gradeability	° ±15
Extension stroke	m	0.7	Water spray system	High pressure water jet
Gathering width	m	4.0	Oil tank capacity	L 800
Gathering arm revolution	min ⁻¹	24/29-50/60Hz	Supply voltage	V 1000/1100-50/60Hz
Loading capacity	m ³ /min	Max. 4.8/5.8-50/60Hz	Required power	KVA more than 500

Note : Above specifications are may be changed without notice.



MITSUI MIIKE MACHINERY CO.,LTD.

MITSUI NO.2 BUILDING, 2-1-1, NIHONBASHI-MUROMACHI, CHUO-KU, TOKYO JAPAN

TEL : 813-3270-2006 FAX : 813-3245-0203

<http://www.mitsumiike.co.jp> E-mail overseas@mitsumiike.co.jp

GENERAL DRAWING

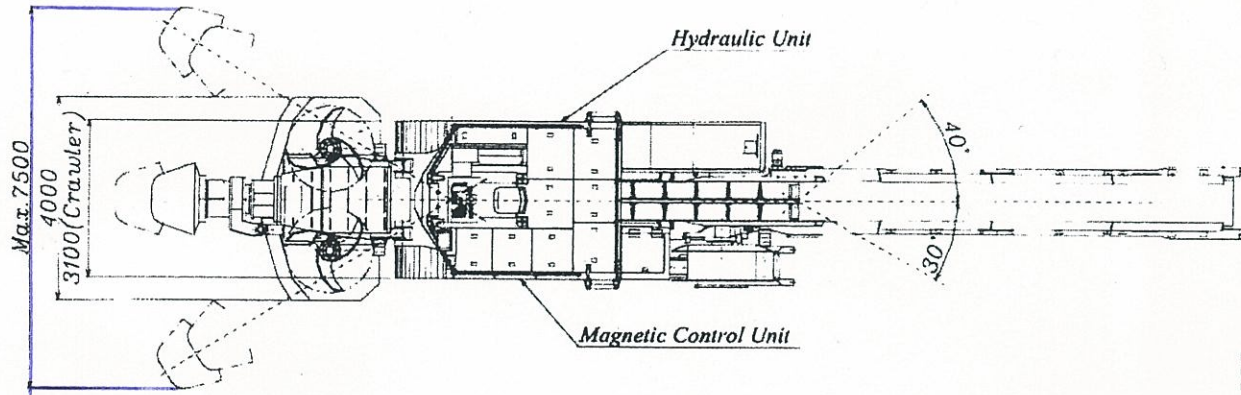

CUTTING RANGE

